

 **cinelli**
2025 line



2025 bicycles and frames line

PLEASE NOTE SPECS MAY VARY.

index

04 - 2025 year product overview

10 - road

30 - gravel

50 - adventure

62 - urban



2025 year



product overview

ROAD

GRAVEL

ADVENTURE

URBAN



pressure II p. 10
Aero road race, crits and grand tours



king zydeco II p. 30
The fastest and lightest gravel bike ever made by Cinelli



hobootleg p. 50
Unsupported long-distance adventure riding



tutto mini silver bootleg p. 62
Bmx meets fixed meets gravel, fast and fun city (and beyond) riding



vigorelli p. 74
Fixed gear icon, velodrome-tuned



pressure adr p. 14
Long distance racer, grand tours and epic rides



king zydeco p. 34
Fast gravel and epic racing



hobootleg geo p. 54
Unsupported off-road long distance adventure riding



zydeco silver bootleg p. 66
Fast, all conditions, commuting and gravel riding



vigorelli steel p. 78
Stylish, practical, city riding and weekend adventures



superstar p. 18
The ultimate all-rounder: gran fondos, climbing, descending & sprinting



zydeco p. 36
Go anywhere gravel, road, light bikepacking and fast commuting



hobootleg easy travel p. 58
Unsupported long-distance adventure riding



tutto plus silver bootleg p. 70
Multi-purpose singlespeed, fast urban and light gravel



nemo tig road p. 22
Handmade in Italy, endurance racing and epic rides



zydeco electric mud p. 42
Fast, ultralight, electric gravel riding



nemo tig road rim p. 26
Handmade in Italy, endurance racing & epic rides



nemo tig gravel p. 46
handmade in Italy, extreme gravel riding and ultra racing



made in milano

manufacturing excellence at cinelli's hq

At Cinelli, we take immense pride in the craftsmanship and precision that go into every Nemo frame. All Cinelli Nemo frames are meticulously manufactured at our headquarters in Milan, Italy. This centralization of production within our Milanese HQ represents one of the most efficient supply chains in the cycling industry. Our unique advantage stems from the close proximity of our sister company, Columbus, which shares the same premises. This arrangement allows for seamless collaboration and communication across design, engineering, manufacturing, and tubing departments, ensuring that every frame meets our exacting standards.



enhanced product design and quality control

The internal frame-building process not only shortens the supply chain but also enhances product design and features. The rapid prototyping capabilities afforded by our integrated operation enable us to quickly iterate and refine our designs. The close-knit interaction between different departments ensures that each frame is crafted with precision and rigorously tested for quality. This meticulous attention to detail guarantees that every Cinelli Nemo frame that leaves our headquarters is of the highest quality, ready to deliver exceptional performance and reliability to cyclists around the world with the finest frames crafted in the heart of Milan.



made in milano

simplified colour choice

In 2025, we have streamlined the range of colour choices available for the Nemo to better serve our customers and assist dealers in presenting our products more effectively. We have introduced a predefined decal colour that will be consistent across all models, complemented by six continuous colours. This thoughtful selection simplifies the decision-making process for customers, ensuring they can easily find a Nemo frame that suits their style and preferences. Additionally, the simplified colour range helps dealers host accurate and appealing in-store displays, making it easier for customers to understand and appreciate the different options available.

- green pink
- gold pink
- pearl white
- green
- curry yellow
- brown



introducing the colour of the year 2025: oatmilk

One of the most exciting updates to the Nemo range for 2025 is our new “Colour of the Year” project.

This initiative showcases a fresh, youthful graphic scheme and a distinctive new colour that will be available exclusively for the year 2025 across all Nemo platforms. The 2025 Colour of the Year is OATMILK. This unique and stylish shade will be offered for one year only, making it a special and limited-edition option for our customers around the world.



pressure II

The ultimate Italian aerodynamic high-speed road riding experience. New and improved 100% Milanese design.





pressure II

frame-kit - complete bike

- Reduced weight (-109 g)
- Modified carbon fiber layup for improved ride quality and reliability
- Increased tyre clearance (32mm)
- 100% Milanese design
- UCI approved
- Full pro features:
 - racing geometry
 - over benchmark stiffness
 - aero-enhanced tubing profiles
 - integrated cables



Born to race, Pressure is the pinnacle of Cinelli's road bike design language. Obsessively re-engineered seatpost length, clamp mechanism and cable guides reduce the weight of the Pressure II framekit by 5% relative to its predecessor. Refined over 4 different samples the Pressure II's carbon fiber layup represents what our R&D team and pro riders believe to be the best ratio between weight savings, race stiffness and reliability. In line with most recent studies in aerodynamics, rolling resistance and - most importantly - the continuous hybridization of the road bike, the Pressure II features 32mm max tyre clearance.



specs

FRAME WEIGHT (M)	FORK WEIGHT (M)	PRESS FIT	MAX TYRE
975 g	390 g	BB 86,5	32 mm

Racing White Patina



Dandy's Racing Green

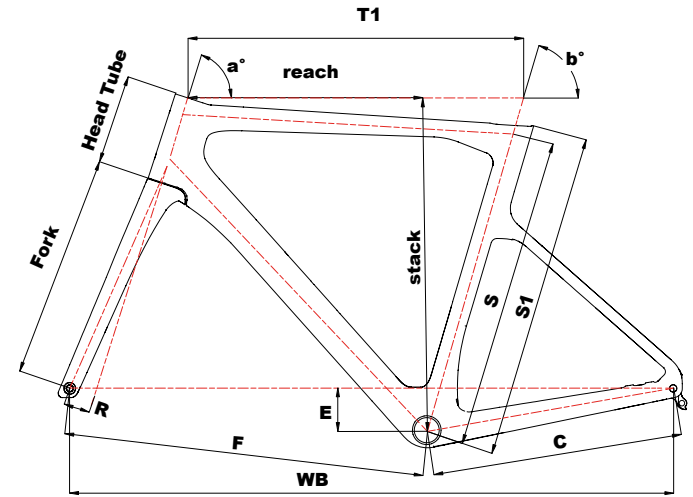

geometry

	S1	S	T1	T	H/T	A	B	R	C	F	WB	E	FORK	STACK	REACH
XS	460	\	518	\	119	71	73,5	45	410	571	971	68	365	512	366
S	490	\	530	\	134	71,5	73,5	45	410	579	979	68	365	528	374
M	520	\	545	\	144	72	73,5	45	410	590	990	68	365	539	385
L	550	\	560	\	164	72,5	73,5	45	410	600	1000	68	365	560	394
XL	580	\	575	\	184	73	73,5	45	410	611	1011	68	365	581	403

assembly

	RED ETAP axs	DURA-ACE DISC DI2	ULTEGRA DISC DI2	105 DISC DI2
Drivetrain	Sram Red Etap AXS	Shimano Dura-Ace 9270	Shimano Ultegra 8150	Shimano 105 7170
Handlebar	Pressure 2 Carbon Handlebar	Pressure 2 Carbon Handlebar	Pressure 2 Carbon Handlebar	Pressure 2 Carbon Handlebar
Stem	/	/	/	/
Seatpost	Integrated	Integrated	Integrated	Integrated
Shifters	Sram Red Etap AXS	Shimano Dura-Ace R9270	Shimano Ultegra R8170	Shimano 105 R7170
Brakes	Sram Red	Shimano Dura-Ace R9270	Shimano Ultegra R8170	Shimano 105 R7170
Rotors	Sram Paceline X 160 - 140 mm	Shimano 160 - 140 mm	Shimano 160 - 140 mm	Shimano 160 - 140 mm
Ft. derailleur	Sram Red Etap AXS	Shimano Dura-Ace R9250	Shimano Ultegra R8150	Shimano 105 R7150
R. derailleur	Sram Red Etap AXS	Shimano Dura-Ace R9250	Shimano Ultegra R8150	Shimano 105 R7150
Crankset	Sram Red Etap AXS 48/35t	Shimano Dura-Ace R9200 52/36t	Shimano Ultegra R8100 52/36t	Shimano 105 R7100 52/36t
Cassette	Sram Red Etap AXS 10/30t	Shimano Dura-Ace R9200 11/30t	Shimano Ultegra R8101 11/30t	Shimano 105 R7101 11/34T
Chain	Sram Red Flathead	Shimano M8100	Shimano M8100	Shimano M7100
Wheelset	Fulcrum Wind 42	Fulcrum Wind 42	Fulcrum 600	Fulcrum 600
Tyres	Pirelli PZero Race 700x28	Pirelli PZero Race 700x28	Vittoria Zaffiro Pro 700x28	Vittoria Zaffiro Pro 700x28
Saddle	Selle Italia Novus Boost	Selle Italia Novus Boost	Selle Italia Model X	Selle Italia Model X

frame specs

Sizes	XS (46) - S (49) - M (52) - L (55) - XL (58)
Concept	XS 90x370 - S 100x390 - M 110x390 - L 110x390 - XL 120x410 (Included)
Material	Columbus Carbon Monocoque T800
Headset	IS 52/28,6 IS 52/40 FSA ACR 1-1/2" (included)
Seatpost	Full Carbon Aero (included) / Carbon Rail Comp.
Seat Clamp	Hidden (included)
BB Shell	Press Fit 86,5 x 41 mm
Ft. derailleur	Braze-On
Routing	Full Internal - Electronic Groupset Only
Color	Racing White Patina / Dandy's Racing Green
Tyre Clear.	up to 700x32 mm
Fork	Full Carbon Monocoque 1-1/8" - 1-1/2" Full Internal Cable Routing
Weight	Frame 975g (size M) - Fork 390g (uncut) (+/- 5% - raw finish)
Brake	Flat Mount Disc Brake, Rotor Size Up To 160 mm
Dropouts ST	Rear TA Ø 12x142mm - M12x165 / Front TA Ø 12x100mm - M12x119
Highlights	Extra hanger / Ft.-Re. Skewers

pressure adr

Pressure ADR takes the racing technology of the Pressure and re-engineers it for improved comfort and handling for endurance and long-distance riding, without losing the pure race feel.





pressure adr

frame-kit - complete bike

- Tuned for ultimate racing comfort
- Aggressive rider position
- Integrated seatpost clamp and cable routing
- Possibility to customize build with after-market components thanks to the standard seat post and fork steerer diameters



The Pressure ADR continues to refine the design and performance developments of our aero-racer, the Pressure fine tuning it for epic, long-distance racing. The ADR in fact maintains the signature pure competition handling and feek of the Pressure, fine-tuning tube sections and carbon fiber lay-up to make it more suitable for long hours in the saddle. These engineering considerations are complemented by fully-integrated cable routing and the use of standard seatpost and fork steerer diameters, allowing the owner to easily install world-leading after market component solutions.

specs

FRAME WEIGHT (M)	FORK WEIGHT (M)	PRESS FIT	MAX TYRE
990 g	420 g	BB 86,5	30 mm

Sun Faded Laser Blue



Midnight Scream



assembly semi-hidden cable routing

	DURA-ACE DISC D12	ULTEGRA DISC D12	105 DISC D12	105 DISC	ULTEGRA DISC 11v
Colour	All Colours	All Colours	All Colours	All Colours	All Colours
Drivetrain	Shimano Dura-Ace 9270	Ultegra Di2 12v	105 Di2	105 Disc	Ultegra Disc 11v
Handlebar	Cinelli Vai	Cinelli Vai	Cinelli Vai	Cinelli Vai	Cinelli Vai
Stem	Alu 6061	Alu 6061	Alu 6061	Alu 6061	Alu 6061
Seatpost	Cinelli Vai ø 27,2	Cinelli Vai ø 27,2	Cinelli Vai ø 27,2	Cinelli Vai ø 27,2	Cinelli Vai ø 27,2
Shifters	Shimano Dura-Ace R9270	Shimano Ultegra R8170	Shimano 105 R7170	Shimano 105 R7120	Shimano Ultegra R8020
Brakes	Shimano Dura-Ace R9270	Shimano Ultegra R8170	Shimano 105 R7170	Shimano 105 R7170	Shimano Ultegra R8070
Rotors	Shimano 160 - 140 mm	Shimano 160 - 140 mm	Shimano 160 - 140 mm	Shimano 160 - 140 mm	Shimano 160 - 140 mm
Ft. derailleur	Shimano Dura-Ace R9250	Shimano Ultegra R8150	Shimano 105 R7150	Shimano 105 R7100	Shimano Ultegra R8000
R. derailleur	Shimano Dura-Ace R9250	Shimano Ultegra R8150	Shimano 105 R7150	Shimano 105 R7100	Shimano Ultegra R8000
Crankset	Shimano Dura-Ace R9200 52/36t	Shimano Ultegra R8100 52/36t	Shimano 105 R7100 52/36T	Shimano 105 R7100 52/36T	Shimano Ultegra R8000 52/36t
Cassette	Shimano Dura-Ace R9200 11/30t	Shimano Ultegra R8100 11/30t	Shimano 105 R7100 11/34T	Shimano 105 R7100 11/34T	Shimano Ultegra R8000 11/30t
Chain	Shimano M8100	Shimano M8100	Shimano M7100	Shimano M7100	Shimano Ultegra R8000
Wheelset	Fulcrum Wind 42	Fulcrum 600	Fulcrum 600	Shimano RS171	Fulcrum 600
Tyres	Pirelli PZero Race 700x28	Vittoria Zaffiro Pro 700x28	Vittoria Zaffiro Pro 700x28	Vittoria Zaffiro Pro 700x28	Vittoria Zaffiro Pro 700x28
Saddle	Selle Italia Novus Boost	Selle Italia Model X	Selle Italia Model X	Selle Italia Model X	Selle Italia Model X

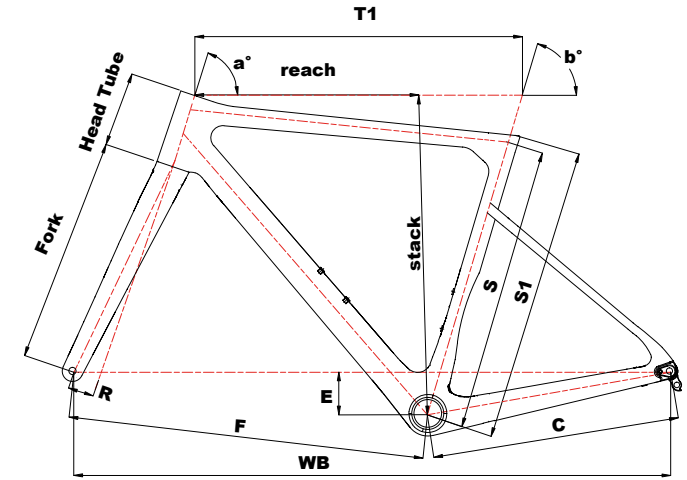

geometry

	S1	T1	H/T	A	B	R	C	F	WB	E	FORK	STACK	REACH
XS	450	519	112	71	74	50	406	582	978	70	373	512	372
S	480	537	123	71,5	73,5	50	406	592	988	70	373	524	382
M	510	555	138	71,8	73	50	408	600	998	70	373	540	389
L	540	572	158	72	72,5	50	408	610	1008	70	373	560	395
XL	570	590	180	72,7	72	50	408	619	1017	70	373	583	403

frame specs

Sizes	XS (45) - S (48) - M (51) - L (54) - XL (57)
Cockpit	/
Material	Columbus Carbon Monocoque
Headset	IS 52/28,6 IS 52/40
Seatpost	ø 27,2
Seat Clamp	Hidden (included)
BB Shell	Press Fit 86,5 x 41 mm
Ft. derailleur	Braze-On
Routing	Full Internal - Di2/EPS Compatible
Color	Sun Faded Laser Blue / Midnight Scream
Tyre Clear.	up to 700x30 mm
Fork	Columbus Disc 1-1/2" Carbon Monocoque Internal Cable Routing
Weight	Frame 990g (size M) - Fork 420g (uncut)
Brake	Flat Mount Disc Brake, Rotor Size Up To 160 mm
Dropouts ST	Rear TA Ø 12x142mm - M12x162 / Front TA Ø 12x100mm - M12x120
Highlights	Ft.-Re. Skewers, Headset, Stem

superstar

Superstar is Cinelli's beloved carbon fiber re-interpretation of the Italian stage-racing bicycle that is the brand's heritage and DNA.





21

GRUPPO SPORTIVO TEAM 19



19

TEAM

TEAM LIMITED

Snelli

LRSUS

LRSUS

LRSUS

LRSUS

LRSUS

LRSUS

BASSANO NOTTE EUROPEA



ENICO 28

EQUIPE 312



superstar

frame-kit - complete bike

- Beloved by riders for its smart mix of low-weight, aggressive handling over highly varied terrain and long-distance riding comfort
- Classic Italian grand tour geometry
- Shaped for maximum control and efficiency of carbon fiber lay up
- 12mm thru-axle



The Superstar is Cinelli's carbon fiber re-interpretation of the Italian stage-racing bicycle that is the brand's heritage and DNA. When developing the Superstar, Cinelli engineers studied how the inherent qualities of carbon fiber and its manufacturing processes could be employed to produce a contemporary iteration of the legendary versatility of the Italian Grand Tour ride quality i.e. the intelligent balance of low-weight, aggressive handling over highly varied terrain and long-distance riding comfort. In fact, owners of the Superstar will always tell you what they love most about the bike is its superlative ride quality!



specs

FRAME WEIGHT (M)	FORK WEIGHT (M)	BOTTOM BRACKET	MAX TYRE
1140 g	440 g	BB 86,5	28 mm

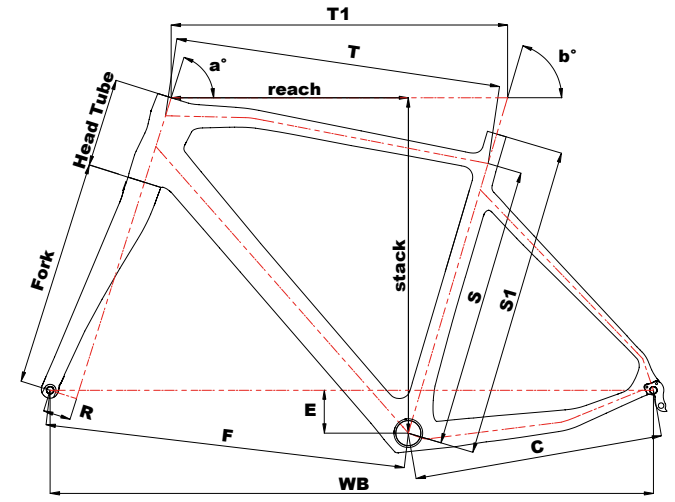

geometry

	S1	S	T1	T	H/T	A	B	R	C	F	WB	E	FORK	STACK	REACH
XS	460	407	515	500	110	71	75	45	415	577	982	70	368	509	373
S	480	430	533	517	120	72	74	45	415	581	987	70	368	522	383
M	510	460	550	533	145	72,5	73,5	45	415	590	995	70	368	548	387
L	540	498	566	550	160	73	73	45	415	595	1001	70	368	564	393
XL	570	523	585	568	185	73,5	72,5	45	415	604	1009	70	368	590	399

assembly

	105 DISC DI2	ULTEGRA DISC 11v
Colour	Dark Night	Dark Night
Drivetrain	105 Di2	Ultegra Disc 11v
Handlebar	Cinelli Vai	Cinelli Vai
Stem	Cinelli Vai	Cinelli Vai
Seatpost	Cinelli Vai ø 27,2	Cinelli Vai ø 27,2
Shifters	Shimano 105 R7170	Shimano Ultegra R8020
Brakes	Shimano 105 R7170	Shimano Ultegra R8070
Rotors	Shimano 160 - 140 mm	Shimano 160 - 140 mm
Ft. derailleur	Shimano 105 R7150	Shimano Ultegra R8000
R. derailleur	Shimano 105 R7150	Shimano Ultegra R8000
Crankset	Shimano 105 R7100 50/34T	Shimano Ultegra R8000 52/36T
Cassette	Shimano 105 R7100 11/34T	Shimano Ultegra R8000 11/30T
Chain	Shimano M7100	Shimano Ultegra R8000
Wheelset	Fulcrum 600	Fulcrum 600
Tyres	Vittoria Zaffiro Pro 700x28	Vittoria Zaffiro Pro 700x28
Saddle	Selle Italia Model X	Selle Italia Model X

frame specs

Sizes	XS (46) - S (48) - M (51) - L (54) - XL (57)
Material	Columbus Carbon Monocoque T700
Headset	IS 42/28,6 IS 52/40 Columbus Compass 1-1/2" incl.
Seatpost	Ø 27,2 mm
Seat Clamp	Ø 31,8 mm
BB Shell	Press Fit 86,5 x 41 mm
Ft. derailleur	Braze-On
Routing	Internal - Di2/EPS compatible
Color	Dark Night
Tyre Clear.	up to 700x28 mm
Fork	Columbus Futura Disc 1-1/8" - 1-1/2" Carbon Monoc.
Weight	Frame 1140 g. (size M) Fork 440 g. (uncut)
Brake	Flat mount disc brake, rotor size up to 160mm
Dropouts ST	Rear TA Ø 12x142mm - M12x167 / Front TA Ø 12x100mm - M12x119
Highlights	Extra hanger / Di2 / EPS cable inserts / F-R Skewers

nemo tig road

Cinelli's 100% Made in Milano steel road flagship hybridizes heritage with contemporary performance to create a new icon of Il Grande Ciclismo.





nemo tig road

frame-kit - complete bike

- T47 bottom bracket allows for full internal cable routing (including Columbus Trittico cockpit) as well as improved stiffness
- Ultralight CNC aluminium seatpost collar reduces weight and improves product life
- seatpost tube and diameter reduces weight and improves comfort
- As of March 2023 all Nemo frames are manufactured within the Cinelli Milan HQ by our internal framebuilder allowing us to create the world's shortest supply chain for premium road bikes.
- Lasercut minimalist brake bridge for further weight savings
- Geometry
- Custom drawn Columbus Spirit triple-butted tubes
- Increased tyre clearance 32mm
- Classic Italian racing geometry
- Design-driven detailing and finish
- Available in 6 different paint
+ 1 Colour of the Year



specs

FRAME WEIGHT (M)	FORK WEIGHT (M)	BOTTOM BRACKET	MAX TYRE
2000 g	392 g	T47	32 mm

The Nemo is Cinelli's flagship steel road bike, handcraft to hybridize our more than 75 years of Italian cycling heritage with the performance possibilities of contemporary cold-drawn steel tubing technology. Every Nemo frame is handwelded by Cinelli's internal framebuilder in its Milanese HQ, using custom drawn triple butted tube drawn by its sister company Columbus, less than 100 metres from the framebuilder creating the world's shortest performance bicycle supply chain.

Thanks to continuous three-way dialogue between the Cinelli design office, our framebuilder and Columbus – the Nemo has undergone subtle but significant manufacturing improvements including a 205g weight reduction (size Medium), the introduction of the T47 bottom bracket allowing for fully-internal cable routing as well as improving stiffness and a new ultralight CNC'd aluminium seatpost collar.

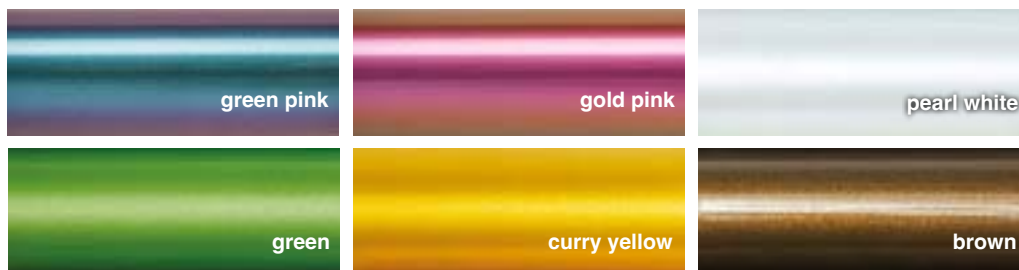

assembly

	SUPER RECORD WRL	RED ETAP axS	DURA-ACE DISC DI2	ULTEGRA DISC DI2	105 DISC DI2
Drivetrain	Campagnolo S.Record WRL	Sram Red Etap AXS	Shimano Dura-Ace 9270	Shimano Ultegra 8170	Shimano 105 7100
Handlebar	Columbus Comp. Trittico	Columbus Comp. Trittico	Columbus Comp. Trittico	Cinelli Vai	Cinelli Vai
Stem	Columbus Comp. Trittico	Columbus Comp. Trittico	Columbus Comp. Trittico	Cinelli Vai	Cinelli Vai
Seatpost	Columbus Comp. Trittico	Columbus Comp. Trittico	Columbus Comp. Trittico	Cinelli Vai Ø 27,2	Cinelli Vai Ø 27,2
Shifters	Super Record WRL	Sram Red Etap AXS	Shimano Dura-Ace R9270	Shimano Ultegra R8170	Shimano 105 R7170
Brakes	Super Record WRL	Sram Red	Shimano Dura-Ace R9270	Shimano Ultegra R8170	Shimano 105 R7170
Rotors	Campagnolo 160 - 140 mm	Sram Paceline X 160 - 140 mm	Shimano 160 - 140 mm	Shimano 160 - 140 mm	Shimano 160 - 140 mm
Ft. derailleur	Super Record WRL	Sram Red Etap AXS	Shimano Dura-Ace R9250	Shimano Ultegra R8150	Shimano 105 R7150
R. derailleur	Super Record WRL	Sram Red Etap AXS	Shimano Dura-Ace R9250	Shimano Ultegra R8150	Shimano 105 R7150
Crankset	Super Record Carbon 48/32t	Sram Red Etap AXS 48/35t	Shimano Dura-Ace R9200 52/36t	Shimano Ultegra R8100 52/36t	Shimano 105 R7100 50/34
Cassette	Super Record 10/29t	Sram Red Etap AXS 10/30t	Shimano Dura-Ace R9200 11/30t	Shimano Ultegra R8101 11/30t	Shimano 105 R7101 11/34T
Chain	Super Record	Sram Red Flathead	Shimano R8100	Shimano R8100	Shimano M7100
Wheelset	Bora Ultra WTO 45 C23	Fulcrum Wind 42	Fulcrum Wind 42	Fulcrum 600 DB	Fulcrum 600 DB
Tyres	Pirelli PZero 700x28	Pirelli PZero 700x28	Pirelli PZero 700x28	Vittoria Zaffiro Pro 700x28	Vittoria Zaffiro pro 700x28
Saddle	Selle Italia Novus	Selle Italia Novus	Selle Italia Novus	Selle Italia Model X	Selle Italia Model X

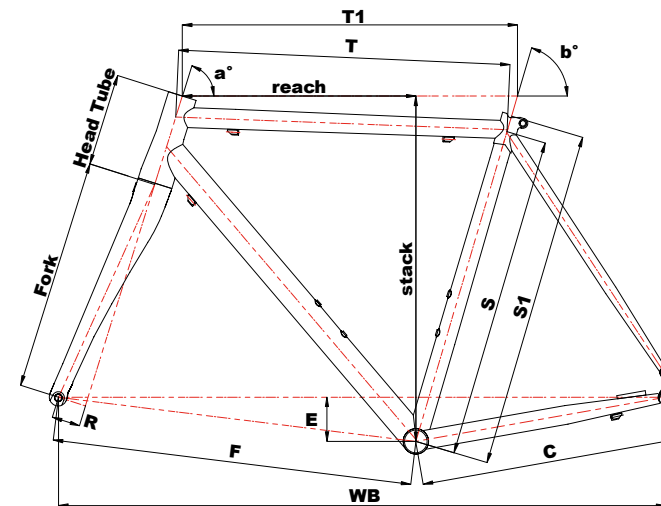

geometry

	S1	T1	H/T	A	B	R	C	F	WB	E	FORK	STACK	REACH
XS	480	510	110	71	74,5	45	410	572	972	70	368	509	369
S	510	525	130	71,5	74	45	410	579	978	70	368	530	373
M	540	545	145	72,5	73,5	45	410	585	985	70	368	548	383
L	560	555	165	73	73,5	45	410	590	990	70	368	568	387
XL	590	575	185	73	73	45	415	605	1010	70	368	588	395
XXL	610	590	210	73,5	73	45	415	614	1019	70	368	613	402

frame specs

Sizes	XS (48) - S (51) - M (54) - L (56) - XL (59) - XXL (61) / Made to Measure
Material	Columbus Spirit HSS Tubaset
Headset	IS 42/28,6 IS 52/40
Seatpost	Ø 27,2 mm
Seat Clamp	CNC Machined ø 29,8
BB Shell	T47 68 mm
Ft. derailleur	Clamp Ø 28,6 mm
Routing	Full Internal (Super Record, Red, Dura-Ace) - External / Internal Hydraulic Disc Brake Housing
Color	Colour of the Year (+6 Custom colors)
Tyre Clear.	up to 700x32 mm
Fork	Columbus Trittico Carbon Road
Weight	Frame 2000 g. (size M) Fork 392 g. (uncut)
Brake	Flat Mount Disc Brake, rotor size up to 160 mm
Dropouts ST	Rear TA Ø 12x142mm - M12x173 / Front TA Ø 12x100mm - M12x119
Highlights	Frame / Fork / Ft. Derailleur Clamp / Ft. & Re. Skewers / Headset

nemo tig road rim

Cinelli's 100% Made in Milano steel road flagship hybridizes heritage with contemporary performance to create a new icon of Il Grande Ciclismo. Here in the traditional version with rim brake.





nemo tig road rim

frame-kit made to order

- Custom drawn Columbus Spirit triple-butted tubes
- Classic Italian racing geometry
- Design-driven detailing and finish



The Nemo is Cinelli's flagship steel road bike, handcrafted to hybridize our more than 75 years of Italian cycling heritage with the performance possibilities of contemporary cold-drawn steel tubing technology. Every Nemo frame is hand welded by Cinelli's internal frame builder in its Milanese HQ, using custom drawn triple butted tube drawn by its sister company Columbus, less than 100 metres from the frame builder, therefore creating the world's shortest performance bicycle supply chain.



specs

FRAME WEIGHT (M)	FORK WEIGHT (M)	BOTTOM BRACKET	MAX TYRE
1800 g	350 g	BSA	28 mm

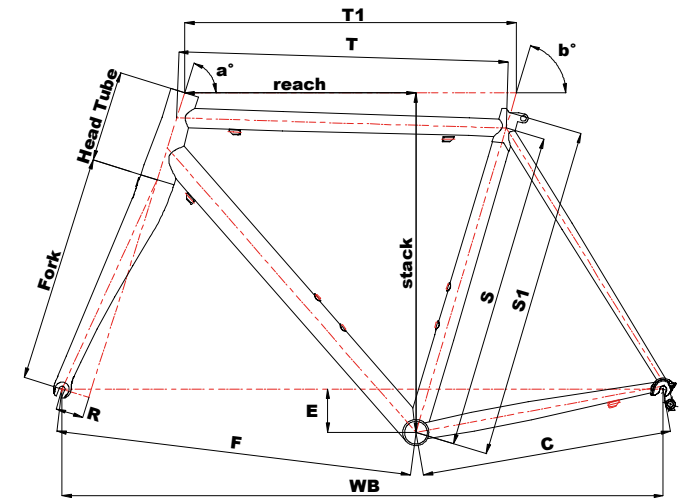
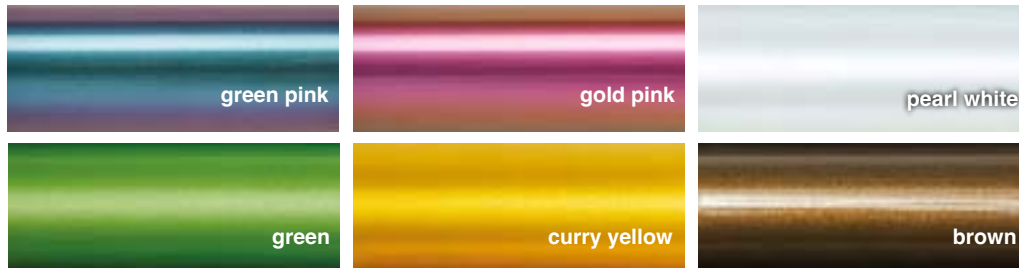

geometry

	S1	S	T1	T	H/T	A	B	R	C	F	WB	E	FORK	STACK	REACH
XS	480	455	510	506	110	71	74,5	45	405	572	967	70	368	510	369
S	510	485	520	516	120	71,5	74	45	405	573	968	70	368	520	371
M	540	515	535	531	145	72,5	73,5	45	405	575	969	70	368	547	373
L	560	535	550	545	160	73	73,5	45	405	585	980	70	368	564	383
XL	590	565	575	570	185	73	73	45	408	605	1003	70	368	587	395
XXL	610	585	590	584	210	73,5	72,5	45	410	609	1005	70	368	613	397

frame specs

Sizes	XS (48) - S (51) - M (54) - L (56) - XL (59) - XXL (61) / Made to Measure
Material	Columbus Spirit HSS Tubeset
Headset	IS 42/28,6 IS 52/40
Seatpost	Ø 27,2 mm
Seat Clamp	Clamp diam. 29,8mm
BB Shell	BSA 68 mm / Press Fit 86,5 x 41 (Custom)
Ft. derailleur	Clamp Ø 28,6 mm
Routing	External
Color	Colour of the Year (+6 Custom colors)
Tyre Clear.	up to 700x28 mm
Fork	Columbus Futura Caliper 1-1/8" - 1-1/2" Carbon Monoc.
Weight	Frame 1800 g. (size M) Fork 350 g. (uncut)
Brake	Standard Rim Brake
Dropouts ST	Front QR 100 mm - Rear QR 130 mm
Highlights	Frame / Fork / Ft. Derailleur Clamp / Headset

king zydeco II

King Zydeco II is the fastest and lightest gravel bike ever made by Cinelli. Perfect for UCI gravel races, Endurance races, fast mixed surface rides, winter training.





king zydeco II

frame-kit - complete bike

- 15% lighter than previous generation
- Columbus Components Allroad Cockpit and Seatpost reduce weight and increase reactivity and visual prestige
- Double Response layup and design system for best handling experience
- Full cable integration
- Fine-tuned fast gravel geometry
- Signature Cinelli attention to details design



When assembled with its proprietary Allroad cockpit and seatpost, the Zydeco King II framekit is an impressive 400g lighter than the original King Zydeco framekit, while stiffness values remain relatively in-line, with a significant increase in Bottom Bracket's (5%) and frontal stiffness. Furthermore the new King Zydeco II maintains the Dual Response System and the race-proven geometry of the King Zydeco, while adding an extra size (XS) and a more linear progression of stack and reach between sizes to improve tailored bike-fitting. Cinelli's signature attention to detail include the sleek modernist shape of its profile, the full cable integration, the custom top tube cover plate, the clean lines of its proprietary Allroad cockpit and seatpost.



specs

FRAME WEIGHT (M)
1000 g

FORK WEIGHT (M)
465 g

BOTTOM BRACKET
BB 86,5

MAX TYRE
700x45c

Orange Safari



Sage Rover

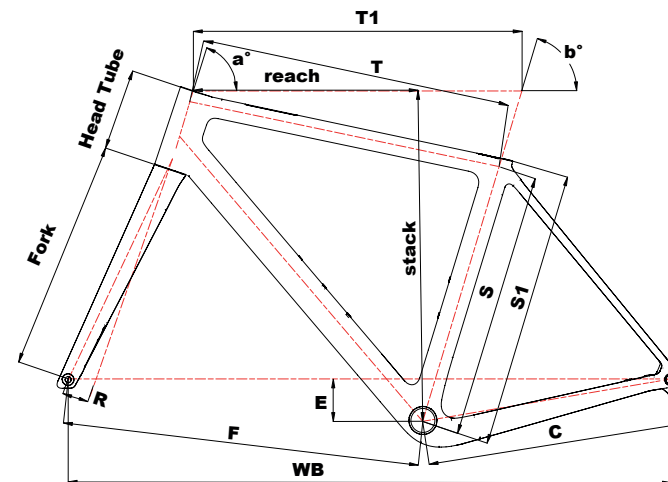

geometry

	S1	S	T1	T	H/T	A	B	R	C	F	WB	E	FORK STACK	REACH	
XS	451	\	520	501	110	70,5	74	52	430	590	1009	72	395	531	362
S	461	\	540	519	125	71	73,5	52	430	601	1021	72	395	549	377
M	469	\	560	537	140	71,5	73	52	430	612	1032	70	395	563	388
L	479	\	580	555	155	72	72,5	52	430	621	1042	70	395	579	397
XL	497	\	600	574	175	72,5	72,5	52	430	636	1054	70	395	600	408

frame specs

Sizes	XS (45) - S (46) - M (47) - L (48) - XL (50)
Cockpit	XS 90x400 - S 90x400 - M 100x420 - L 110x420 - XL 110x440 Included
Material	Columbus Carbon Monocoque
Headset	IS 52/28,6 IS 52/40 FSA ACR 1-1/2" (Included)
Seatpost	Aero (included) / Carbon Rail Comp.
Seat Clamp	Hidden (Included)
BB Shell	Press Fit 86,5 x 41 mm
Ft. derailleur	Braze-On Frame 1x FD Cover Included
Routing	Full Internal - Di2/EPS Compatible
Color	Orange Safari - Sage Rover
Tyre Clear.	up to 700x45 C
Fork	Full Carbon Monocoque 1-1/8" - 1-1/2"
Weight	Frame 1000 g. (size M) Fork 456 g. (uncut) (+/- 5% - raw finish)
Brake	Flat Mount Disc Brake, rotor size up to 160 mm
Dropouts ST	Rear TA Ø 12x142mm - M12x174 / Front TA Ø 12x100mm - M12x121
Highlights	UDH Hanger / Ft. & Re. Skewers
Compatibility	Gravel drivetrain only GRX, Sram Wide and Ekar.

assembly

	GRX di2 2x	EKAR	RIVAL axS XPLR	GRX 820 2x	GRX 610 1x
Drivetrain	Shimano GRX 825	Campagnolo Ekar	Sram Rival AXS XPLR	Shimano GRX 820	Shimano GRX 612
Handlebar	Columbus Comp. Integrated HB	Columbus Comp. Integrated HB	Columbus Comp. Integrated HB	Columbus Comp. Integrated HB	Columbus Comp. Integrated HB
Stem	/	/	/	/	/
Seatpost	Integrated	Integrated	Integrated	Integrated	Integrated
Shifters	Shimano GRX RX825	Campagnolo Ekar	Sram Rival AXS	Shimano GRX RX820	Shimano GRX RX610
Brakes	Shimano GRX RX820	Campagnolo Ekar	Sram Rival Hydro Disc	Shimano GRX RX820	Shimano GRX RX400
Rotors	Shimano 160 mm	Campagnolo Ekar	Paceline 160 mm	Shimano 160 mm	Shimano 160 mm
Ft. derailleur	Shimano GRX RX825	/	/	Shimano GRX RX820	/
R. derailleur	Shimano GRX RX825	Campagnolo Ekar	Sram Rival AXS XPLR	Shimano GRX RX820	Shimano GRX RX822
Crankset	Shimano GRX RX820 48/31t	Campagnolo Ekar 40T	Sram Rival 1 Wide 40t	Shimano GRX RX820 48/31t	Shimano GRX RX 610-1 42t
Cassette	Shimano HG710 11/36t	Campagnolo Ekar 9-42T	Sram Rival XPLR 10/44t	Shimano HG710 11/36t	Shimano M7100 10/45t
Chain	Shimano M8100	Campagnolo Ekar	Sram Rival	Shimano M7100	KMCX 12
Wheelset	Fulcrum Sharq	Fulcrum Rapid Red 500 DB	Fulcrum Rapid Red 500	Fulcrum Rapid Red 500	WTB ST i23 rims - Shimano hubs
Tyres	Pirelli Cinturato H 700x40	Pirelli Cinturato H 700x40	Pirelli Cinturato H 700x40	Pirelli Cinturato H 700x40	Vittoria Terreno Dry 700x40
Saddle	Selle Italia NOVUS Boost	Selle Italia NOVUS Boost	Selle Italia NOVUS Boost	Selle Italia NOVUS Boost	SSM Shortfit

king zydeco

A pioneer of the European gravel riding movement, the King Zydeco is our go-fast-everywhere monocoque carbon fiber frame.





king zydeco

frame-kit - complete bike

- Performance gravel geometry
- Tyre clearance up to 700x47c or 650x2.1"
- Adaptive geometry thanks to Columbus fork dropouts that allow to change the rake from 47 to 52 mm
- Double response stiffness/compliance frame design for best off-road riding experience
- Downtube kevlair shield
- Bike packing ready rivet system

A pioneer of the European gravel riding movement, the King Zydeco is a go-fast-everywhere monocoque carbon fiber frame, perfect for competitive gravel riding and fast touring/endurance racing.

The engineering heart of the frame lies in the mould's transition between top tube and seat stays, specifically developed to allow for fibers to be continuously aligned allowing for significant weight reduction, optimization of the lay up and above all superior distribution of vibration arriving from the rear wheel.

Working in tandem with the oversized tube sections of the down and head tube a "double response system" of finely tuned stiffness and compliance is created. The emotional heart of the frame lies in exploring new attitudes and emotions on adventures you didn't previously think were possible!



specs

FRAME WEIGHT (M)
1000 g

FORK WEIGHT (M)
550 g

BOTTOM BRACKET
BB 386

MAX TYRE
**700x47c
650bx2,1"**



Grey Rock

assembly

	APEX EAGLE 12v	ULTEGRA 11v
Colour	Jet Rock	Grey Rock
Drivetrain	Sram Apex EAGLE	Ultegra Disc 8020
Handlebar	Alloy 6061 12° Flare	Alloy 6061 12° Flare
Stem	Cinelli Vai	Cinelli Vai
Seatpost	Cinelli Vai ø 27,2	Cinelli Vai ø 27,2
Shifters	Sram Apex	Shimano Ultegra R8020
Brakes	Sram Apex	Shimano Ultegra R8070
Rotors	Centreline 160 mm	Shimano 160 mm
Ft. derailleur	/	Shimano Ultegra R8000
R. derailleur	Sram Apex EAGLE	Shimano Ultegra R8000
Crankset	Apex DUB Wide 40t	Shimano Ultegra R8000 46/36t
Cassette	Sram PG1230 11/50t	Shimano Ultegra R8000 11/32t
Chain	Sram Apex	Shimano Ultegra R8000
Wheelset	Rapid Red 500 650b	Rapid Red 500
Tyres	Vittoria Barzo 27,5x2.1	Pirelli Cinturato H 700x40
Saddle	Selle Italia Model X	SSM Shortfit

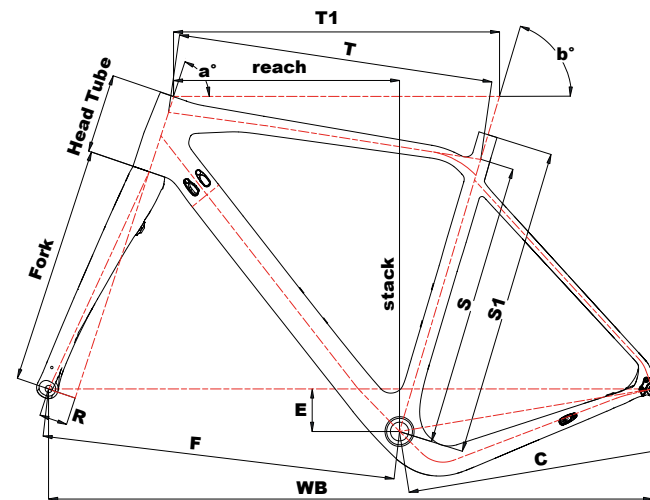

geometry

	S1	S	T1	T	H/T	A	B	R	C	F	WB	E	FORK	STACK	REACH
S	480	435	530	513	100	70	73	47/52	430	588	1010	70	395	519	371
M	510	468	550	530	130	71,5	73	47/52	430	595	1018	70	395	550	380
L	530	493	570	550	150	72,5	72,5	47/52	430	602	1024	70	395	576	389
XL	550	506	590	568	175	72,5	72,5	47/52	430	621	1044	70	395	599	400

frame specs

Sizes	S (48) - M (51) - L (53) - XL (55)
Material	Columbus Carbon Monocoque
Headset	IS 42/28,6 IS 52/40 Columbus Compass 1-1/2" (Included)
Seatpost	Ø 27,2 mm
Seat Clamp	Ø 31,8 mm (Included)
BB Shell	BB386EVO 86,5 x 46 mm
Ft. derailleur	Clamp Ø 31,8 mm
Routing	Internal - Di2/EPS Compatible
Color	Grey Rock - Jet Rock
Tyre Clear.	up to 700x47 C / 27,5x2.1 inc
Fork	Columbus Futura Cross Plus (Jet Rock) Columbus Futura Cross (Grey Rock) 1-1/8"11-1/2" Carb. Monoc.
Weight	Frame 1000 g. (size M) Fork 550 g. (uncut)
Brake	Flat Mount Disc Brake, rotor size up to 160 mm
Dropouts ST	Rear TA Ø 12x142mm - M12x167 / Front TA Ø 12x100mm - M12x132
Highlights	Extra Hanger / Di2 - EPS Cable Insert / Ft. & Re. Skewers

zydeco

Our original gravel bike, loved by riders across the world for its lightweight performance feeling combined with ultra-versatile design details making it ready for both city and mud!





zydeco

complete bike

- Our original gravel bike
- Oversized triple-buttet Columbus Zonal aluminium tubing
- All-weather urban commute to performance gravel adventure versatility
- Custom rivet system allows user endless bag and rack options
- Max tyre clearance 700x40c
- 10,3kg total bike weight



The most beloved of all Cinelli gravel bikes, the Zydeco's appeal lies in the quality of its manufacturing (triple-buttet Columbus Zonal aluminium tubes) and finish as well as its absolute versatility. Beyond its primary function as a performance gravel bike, the Zydeco can quickly morph into a bike-packing vehicle or fast all-weather urban commuter thanks to its exhaustive system of rivets.

specs

BIKE WEIGHT **10,3 Kg** BOTTOM BRACKET **BSA** MAX TYRE **40 mm**

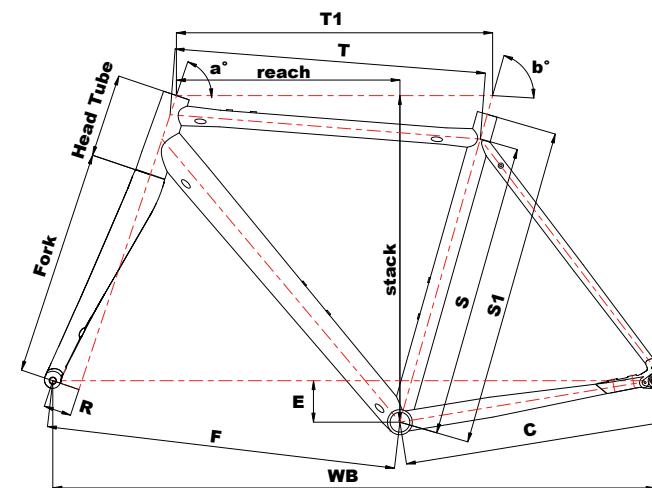

geometry

	S1	S	T1	T	H/T	A	B	R	C	F	WB	E	FORK	STACK	REACH
XS	490	447	510	504	100	70,5	74,5	47	440	580	1010	71	382	510	371
S	510	467	520	514	120	71	74,5	47	440	587	1017	70	382	530	375
M	540	497	539	530	140	71,5	74	47	440	595	1025	70	382	551	380
L	560	517	560	549	160	72	73,5	47	440	606	1037	70	382	572	390
XL	590	547	580	570	180	72,5	73	47	440	617	1047	70	382	592	399

assembly

SHIMANO 1x11

Drivetrain	Shimano
Handlebar	Cinelli Handlebar 6061
Stem	Cinelli Stem 6061
Seatpost	Cinelli Seat Post 6061 Ø 31,6
Shifters	Shimano
Brakes	Shimano
Rotors	Shimano RT54 160mm
Ft. derailleur /	
R. derailleur	Shimano
Crankset	Shimano 40t
Cassette	Shimano 11-50t
Chain	Shimano
Wheelset	Shining DB30 Shimano Hub (RS-470) front & rear
Tyres	WTB Riddler 700x37
Saddle	Cinelli SSM RND

Sage Rover White



frame specs

Sizes	XS (49) - S (51) - M (54) - L (56) - XL (59)
Material	Columbus Zonal Triple Butted Alloy
Headset	IS 42/28,6 IS 47/33
Seatpost	Ø 31,6 mm
Seat Clamp	Ø 34,9 mm
BB Shell	BSA 68 mm
Ft. derailleur	Clamp Ø 34,9 mm
Routing	Internal
Color	Sage Rover White
Tyre Clear.	up to 700x40 mm
Fork	Columbus Futura Allroad 1-1/8" - 1-1/4" Carbon Monocoque
Weight	Frame 1760 g. (size M) Fork 450 g. (uncut)
Brake	Flat Mount, Rotor Size Up to 160 mm
Dropouts ST	Rear TA Ø 12x142mm - M12x165 / Front TA Ø 12x100mm - M12x119
Highlights	Front & Rear Fenders Ready / Rear Rack Eyelets / Fast Fuel Eyelets

zydeco electric mud

An ultralight, true gravel geometry,
E-bike for expanding the horizons
of your off-road riding.





zydeco electric mud

complete bike

- T800 Monocoque carbon frame and fork for 12,8kg complete bike weight
- 100km or 1000m ascent range for new adventures
- Internal hub motor allows for the E-Mud to maintain a 100% pure gravel geometry
- Dedicated app for all functions, custom configurations and detailed info
- Mahle Ebikemotion X35 engine

The Zydeco E-Mud is Cinelli's first e-bike, fruit of our experience developing the iconic King Zydeco. The E-Mud in fact maintains the same geometry and mould features of the King to guarantee a pure, unadulterated fast gravel feeling for the E-Mud. The use of an internal hub in fact allows for shorter chainstays than other Gravel e-bikes on the market and thus a faster, funner ride. Other features include 12,8kg complete bike weight, 100km or 1000m ascent range and a dedicated app for custom configurations and data.



specs

BIKE WEIGHT (M)
12,8 Kg

PRESS FIT
BB 86,5

MAX TYRE
700x44
650bx48

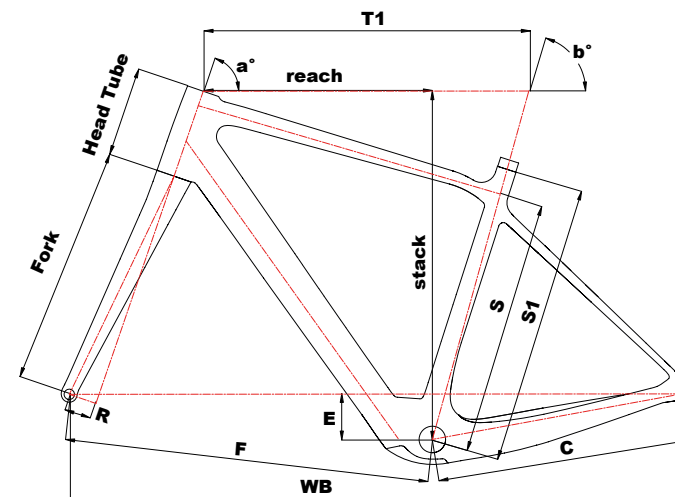

geometry

	S1	S	T1	H/T	A	B	R	C	F	WB	E	FORK	STACK	REACH
S	470	410	525	125	70,5	73	47	423	598	1009	75	402	556	373
M	500	440	549	150	71	72	47	423	611	1023	75	402	582	382
L	530	470	573	175	71,5	72	47	423	624	1041	75	402	608	392

assembly

MAHLE EBIKEMOTION X35 ENGINE + SHIMANO GRX 1X11

Drivetrain	Shimano GRX Mix 1X11
Handlebar	Cinelli 6061
Stem	Cinelli 6061
Seatpost	Cinelli 6061 Ø 27,2
Shifters	Shimano GRX ST-RX400 1X11
Brakes	Shimano GRX 400 BR-RX400
Rotors	Shimano SM-RT70 160mm Center Lock
Ft. derailleur /	
R. derailleur	Shimano GRX RD-RX812
Crankset	Shimano GRX RX600-1 40T
Cassette	Shimano SLX CS-M8000 / 11-42 / 11s
Chain	Shimano CN-HG601
Wheelset	HY-NDR30AC
Tyres	Vittoria Terreno Dry 700x40C
Saddle	Selle Italia Model X

frame specs

Sizes	S (47) - M (50) - L (53)
Material	Columbus Carbon Monocoque
Headset	IS 42/28,6 IS 52/40
Seatpost	Ø 27,2 mm
Seat Clamp	Ø 31,8 mm Included
BB Shell	Press Fit 86,5x41
Ft. derailleur	Braze-on
Routing	Internal - Di2 compatible
Color	Fullcolor
Tyre Clear.	up to 700x44 / 650x48
Fork	Columbus Disc tapered 1-1/2" Carbon Monocoque
Weight	Frame 1420 g. (size M) Fork 450 g. (uncut)
Brake	Flat Mount, Rotor Size Up to 160 mm
Dropouts ST	Front TA Ø12x100mm / M12x1,5 L125mm skewer (incl.) Rear EBIKEMOTION axle std O.L.D. 136mm
Highlights	Di2 cable inserts / Front skewer / Rear carrier eyelets

nemo tig gravel

The ultimate designer gravel bike. Made in Milano, fine-tuned for the world's most extreme gravel adventures.



BAD WORDS
MAKE
GOOD BIKES



nemo tig gravel

frame-kit - complete bike

- Completely re-designed geometry for more extreme terrains
- 700 x 47mm \ 650b x 50mm tyre clearance thanks to our proprietary investment cast yoke
- Designed specifically for Hi-Ride Sterra fork system: 20mm of true hydraulic travel optimized for gravel riding combined with stiffest gravel suspension legs on the market, low maintenance and many other features.
- As of March 2023 all Nemo frames are manufactured within the Cinelli Milan HQ by our internal framebuilder allowing us to create the world's shortest supply chain for premium road bikes.
- Custom-shaped seat stays with oriented ellipses and lowered seat tube welding pointing to optimize long-distance comfort
- Seat collar
- Custom drawn Columbus Spirit triple-butted tubes
- Adaptive geometry on rigid fork option thanks to Columbus fork dropouts that allow to change the rake from 47 to 52 mm
- Design-driven detailing and finish
- Available in 6 different paint + 1 colour of the year



specs

FRAME WEIGHT (M)	FORK WEIGHT (M)	BOTTOM BRACKET	MAX TYRE
2000 g	480 g	T47	47 mm

Radically overhauled, the Nemo Gravel represents our most intensely hybridized and extreme adventure gravel bike ever, entirely handcrafted by Cinelli's internal framebuilder in its Milanese HQ using custom drawn triple butted tube drawn by its sister company Columbus, less than 100 metres from the framebuilding workshop. Continuously refined over a one year period of testing by riders including former UCI World Champions, NYC courier legends, professional snowboarders and many other athletes pushing to redefine the limits of what gravel cycling can be, the Nemo Gravel is characterized above all by its completely redesigned geometry, 700 x 47mm tyre clearance and the use of the Hi-Ride Sterra fork with 20mm of true hydraulic travel. Together these features work to create a bike that is ready to tackle the world's most extreme gravel competitions and adventures.

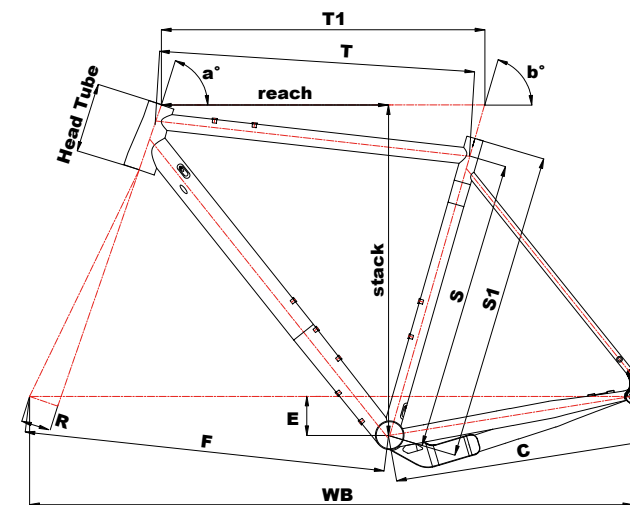

geometry

	S1	T1	H/T	A	B	R	C	F	WB	E	FORK	STACK	REACH
XS	480	528	115	70	74,5	47/52	430	613	1034	68	435	568	374
S	520	548	115	70	74,5	47/52	430	632	1053	68	435	569	391
M	540	565	120	71	74	47/52	430	633	1054	68	435	578	399
L	560	585	130	72	73,5	47/52	430	638	1059	68	435	591	410
XL	590	600	140	72,5	73	47/52	430	642	1063	68	435	603	416
XXL	610	615	160	72,5	73	47/52	430	658	1079	68	435	622	425

frame specs

Sizes	XS (48) - S (52) - M (54) - L (56) - XL (59) - XXL (61) / Made to Measure
Material	Columbus Spirit HSS Tubaset
Headset	IS 42/28,6 IS 52/40 (rigid fork), IS 42/33 IS 52/40 (hi-ride)
Seatpost	∅ 27,2 mm
Seat Clamp	CNC Machine ∅ 29,8
BB Shell	T47 68 mm
Ft. derailleur	Clamp ∅ 28,6mm
Routing	External / Internal Hydraulic Disc Brake Housing
Color	1 Colour of the Year + 6 custom Colours
Tyre Clear.	up to 700x47 mm \ 650b x 50mm
Fork	Hi-ride Sterra 1-1/4" - 1-1/2", Columbus 1-1/8" - 1-1/2" Carbon Monoc.
Weight	Frame 2000 g. (size M) Columbus Fork 480 g. (uncut) / Sterra 1300g
Brake	Flat Mount Disc Brake, rotor size up to 160mm (rear) - 180mm (front)
Dropouts ST	Rear TA ∅ 12x142mm - M12x173 / Front TA ∅ 12x100mm - M12x119
Highlights	Frame / Fork / Ft. Derailleur Clamp / Ft. & Re. Skewers / Headset / Stem

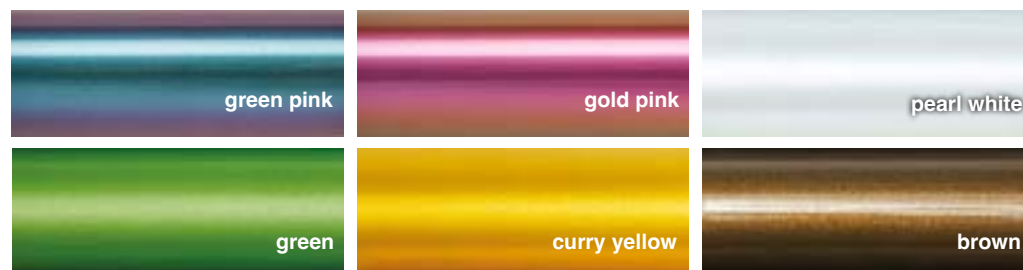

assembly

	EKAR	RIVAL axs XPLR	GRX 1x	GRX 2x
Drivetrain	Campagnolo Ekar	Sram Rival AXS XPLR	Shimano GRX RX822	Shimano GRX RX820
Handlebar	Cinelli Swamp	Cinelli Swamp	Cinelli Swamp	Cinelli Swamp
Stem	Alu 6061	Alu 6061	Alu 6061	Alu 6061
Seatpost	Cinelli Vai ∅ 27,2	Cinelli Vai ∅ 27,2	Cinelli Vai ∅ 27,2	Cinelli Vai ∅ 27,2
Shifters	Campagnolo Ekar	Sram Rival AXS	Shimano GRX RX820	Shimano GRX RX820
Brakes	Campagnolo Ekar	Sram Rival Hydro Disc	Shimano GRX RX820	Shimano GRX RX820
Rotors	Campagnolo Ekar 160mm	Paceline 160 mm	Shimano MT-800 160 mm	Shimano MT-800 160 mm
Ft. derailleur	/	/	/	Shimano GRX RX820
R. derailleur	Campagnolo Ekar	Sram Rival AXS XPLR	Shimano GRX RX822	Shimano GRX RX820
Crankset	Campagnolo Ekar 40T	Sram Rival 1 Wide 40t	Shimano GRX RX820-1 40t	Shimano GRX RX 820 48/31t
Cassette	Campagnolo Ekar 9-42T	Sram Rival XPLR 10/44t	Shimano M7100 10/45t	Shimano HG710 11/36t
Chain	Campagnolo Ekar	Sram Rival	Shimano M7100	Shimano M7100
Wheelset	Fulcrum Rapid Red 500	Fulcrum Rapid Red 500	Fulcrum Rapid Red 500	Fulcrum Rapid Red 500
Tyres	Vittoria Terreno Dry 700x47	Vittoria Terreno Dry 700x47	Vittoria Terreno Dry 700x47	Vittoria Terreno Dry 700x47
Saddle	SSM Shortfit	SSM Shortfit	SSM Shortfit	SSM Shortfit

hobootleg

Fine-tuned over a million kilometres and ten years of riding, the Hobo is our original, indestructible, go-anywhere travelmate. Today, in the new Hobootleg family powder-coated-paintjob, inspired by multiple textures of vintage Land Rover Defender 90.





hobootleg

complete bike

- The world's most reliable adventure bike
- Meticulously fine-tuned details for the most demanding adventures and adventurers
- Double-butted cromor tubes
- Electrophoretic paint
- Tubus racks
- Ovalized handlebar sections
- Spare wheel spokes for on-the-road repairs
- Ready-to-ride anywhere and everywhere, right out of the box
- Steering limitation system (Ergo Steering Stop)
- External cable routing



There is no adventure like a hoboing adventure. Since its original conception for the mythical Tour d'Afrique of 2012, the Hobootleg has been continuously fine-tuned across more than a million kilometres, all of the world's seven highest mountain passes, the Guinness World Record-holding globe crossing and many other adventures to become the world's most reliable adventure bike. Thanks to obsessive details such as double butted cromor tubes, electrophoretic paint, Tubus racks, ovalized handlebar and spare wheel spokes the Hobootleg is ready to ride straight out of the box, anywhere, for as long as you like, any way you like...

specs

BIKE WEIGHT
14,2 Kg

BOTTOM BRACKET
BSA

MAX TYRE
42 mm

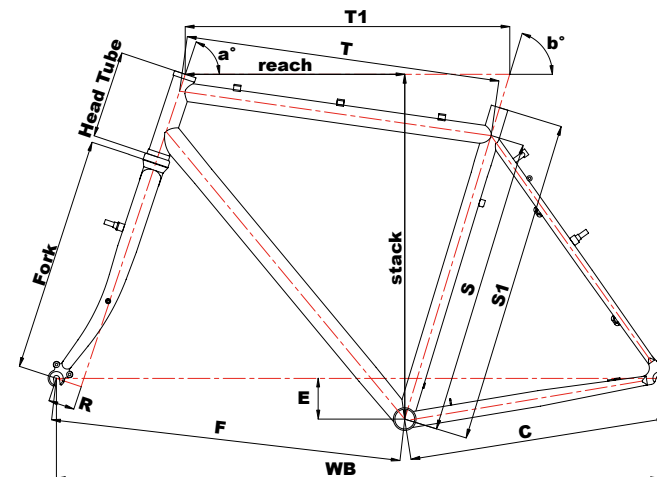

geometry

	S1	S	T1	T	H/T	A	B	R	C	F	WB	E	FORK	STACK	REACH
S	490	440	520	504	105	70	74	45	420	594	1025	70	410	549	362
M	530	480	540	523	125	71	73,5	45	420	600	1031	70	410	572	370
L	560	510	560	543	145	71,5	73	45	420	610	1041	70	410	593	379
XL	590	540	580	563	165	71,5	72,5	45	420	625	1055	70	410	612	387
XXL	610	560	600	579	195	72	72	45	420	634	1064	70	410	643	391

assembly

MICROSHIFT

Drivetrain	Microshift
Handlebar	Cinelli Bootleg
Stem	Cinelli Bootleg
Seatpost	Cinelli 6061
Shifters	Right & Left Microshift (BS-T09) Bar End Shifter / 9 Speed Micro Index Right - 2/3 Speed Index Friction Left
Brakes	Front & Rear Tektro (992AG) / Road Racing Lever Tektro (RL340)
Rotors	/
Ft. derailleur	Microshift (FD-R 353SB)
R. derailleur	Microshift (RD-M46L) - 9 Speed
Crankset	Prowheel Zephyr-701 / 48-36-26t
Cassette	Microshift - 9 Speed - 11-34t
Chain	Kmc (Z9)
Wheelset	Front & Rear AlexRims DM 18 - Shimano Hub (HB-RS300)
Tyres	WTB Riddler 700x37c Tan Sidewall
Saddle	WTB Volt

frame specs

Sizes	S (49) - M (53) - L (56) - XL (59) - XXL (61)
Material	Cromor Double Butted Steel
Headset	EC 34/28,6 EC 34/30
Seatpost	Ø 27,2 mm
Seat Clamp	Ø 29,8 mm
BB Shell	BSA 68 mm
Ft. derailleur	Clamp Ø 28,6 mm
Routing	External, Full Length Housing
Color	Forever Green
Tyre Clear.	Up to 700x38 mm With Fenders - Up to 700x40 mm Without Fenders
Fork	Cr-Mo Steel 1-1/8"
Weight	Frame 2300 g. (size M) - Fork 1250 g. (uncut)
Brake	Cantilever
Dropouts ST	Rear QR 130 mm - Front QR 100mm
Highlights	EDP / Ergo Steering Stop / Bar End Shifters / Ft & Re, Tubus Rack

hobootleg geo

Our most advanced adventure bike ever, takes the characteristics of our indestructible Hobo and tunes them for technical and single-track journeys. Today, in the new Hobootleg family powder-coated-paintjob, inspired by multiple textures and materials of vintage Land Rover Defender 90.





hobootleg geo

frame-kit - complete bike

- Hardtail MTB-derived geometry
- Flared handlebars and 70mm stem for maximum control
- 6-eyelet “go-anywhere” Columbus Futura Adventure fork
- Adaptive geometry thanks to Columbus fork dropouts that allow to change the rake from 47 to 52 mm
- Cromor double-butted steel tubing
- Max tyre clearance 29x3,0”/ 27,5x3,0”
- All specs fine-tuned over a period of three years of testing



The Hobootleg Geo is Cinelli’s most advanced adventure bike ever. It has been designed to take the signature characteristics of our indestructible self-sufficient world-traveller, the original Hobo model, and tweak it for single-track, in particular technical mountain riding. Key features include flared handlebars, 6-eyelet fork, hydraulic disc brake caliper coupled with a mechanical actuator as well as a geometry that is derived from classic rigid mountainbikes. All details have been fine-tuned over a three-year testing period with our adventure ambassadors so that the bike is ready to tackle your most extreme rides straight out of the box without further modification.

specs

BIKE WEIGHT (M)
12,2 Kg

BOTTOM BRACKET
BSA

MAX TYRE
29x3,0"
27,5x3,0"

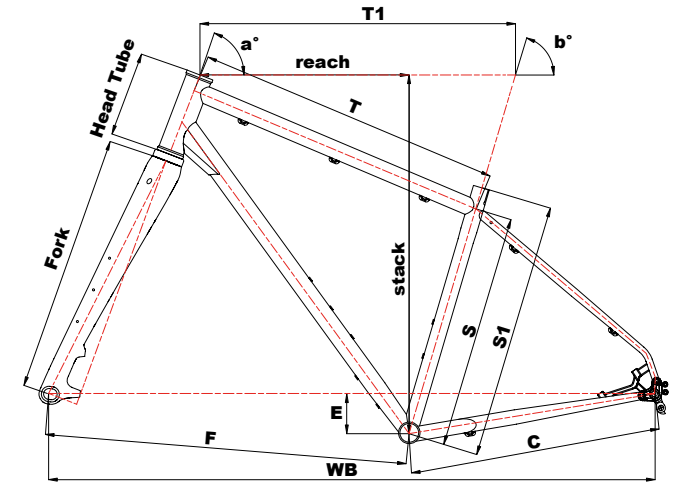

geometry

	S1	S	T1	T	H/T	A	B	R	C	F	WB	E	FORK	STACK	REACH
S	400	360	540	533	133	68	74	45/50	450	642	1083	70	468	620	362
M	460	420	570	552	153	69	73,5	45/50	450	657	1098	70	468	644	379
L	510	470	600	576	173	69	73	45/50	450	682	1123	70	468	663	397
XL	550	510	620	593	193	69	72,5	45/50	450	697	1138	70	468	682	405

assembly

SHIMANO GRX 2x10 Mix

Drivetrain	Shimano GRX 2x10 mix
Handlebar	Cinelli Largo
Stem	Cinelli 6061
Seatpost	Cinelli 6061
Shifters	Shimano Tiagra ST-4700
Brakes	Tektro HD-C705C
Rotors	Tektro 160 mm
Ft. derailleur	Microshift FD-FD-M612-B
R. derailleur	Shimano GRX RD-RX400 / 10 Speed
Crankset	Prowheel (MPL-501-TT) / 36/26T
Cassette	Shimano CS-HG500 / 10 Speed / 11-36T
Chain	Kmc X10
Wheelset	Front & Rear WTb ST i25 TCS 2.0 - 36h - Hubs Shimano (TC-500) Center Lock
Tyres	WTB Ranger / 29x2,25 / Tan Sidewall
Saddle	WTB Volt

frame specs

Sizes	S (40) - M (46) - L (51) - XL (55)
Material	Cromor Double Butted Steel
Headset	ZS 44/28,6 EC 44/40
Seatpost	Ø 27,2 mm
Seat Clamp	Ø 29,8 mm
BB Shell	BSA 73 mm
Ft. derailleur	Clamp on Ø 28,6 mm
Routing	External, Full Length Housing
Color	Forever White
Tyre Clear.	Up to 29x3.0 / 27,5x3.0
Fork	Columbus Carbon Futura Adventure
Weight	Frame 2500 g. (size M) Fork 550 g. (uncut)
Brake	Post Mount Disc Brake, Rotor Size Up To 180 mm
Dropouts ST	Rear TA Ø 12x148mm - M12x170 / Front TA Ø 15x110mm - M15x150
Highlights	Rear Rack Eyelets / Anything Cage Eyelets / Dynamo Housing

hobootleg easy travel

A fast adventure bike for those who prefer STI levers and disc brakes.

Today, in the new Hobootleg family powder-coated-paintjob, inspired by multiple textures and materials of vintage Land Rover Defender 90.





hobootleg easy travel

complete bike

- Fast adventure geometry
- STI levers and bar disc brakes
- 44mm max tyre clearance
- Double-buttet cromor tubes
- Electrophoretic paint

The Easy Travel is a fast adventure bike for those who prefer STI levers to bar ends, disc brakes and less complicated road surfaces. The bike, of course, shares its signature characteristics such as double-buttet cromor tubes and electrophoretic paint with its older-cousin, the indestructible self-sufficient world-travelling Hobootleg.



specs

BIKE WEIGHT	BOTTOM BRACKET	MAX TYRE
12,5 Kg	BSA	44 mm

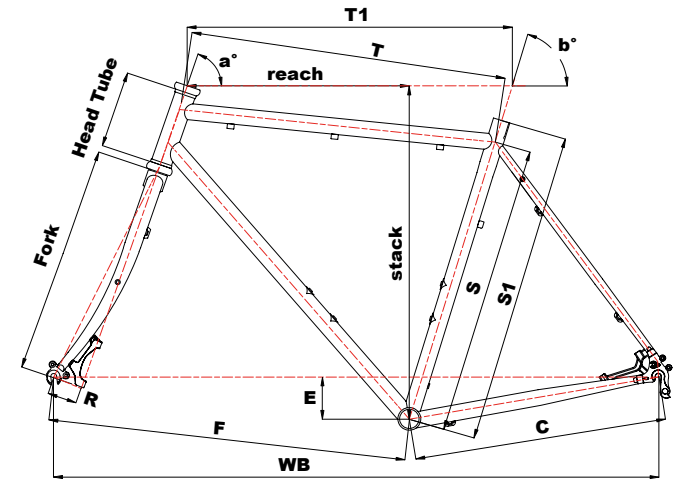

geometry

	S1	S	T1	T	H/T	A	B	R	C	F	WB	E	FORK	STACK	REACH
XS	480	440	520	507	80	70	73	55	440	590	1018	75	400	531	360
S	520	480	545	531	110	71	73	55	440	604	1033	75	400	563	373
M	550	510	564	552	135	71	73	55	440	624	1053	75	400	587	385
L	580	540	591	577	160	71,5	72,5	55	440	640	1069	75	400	612	398
XL	600	560	611	596	185	72	72,5	55	440	657	1086	75	400	638	410

assembly

SWORD 2x10

Drivetrain	Microshift 2x10
Handlebar	Cinelli 6061
Stem	Cinelli 6061
Seatpost	Cinelli 6061
Shifters	Microshift SWORD sb-g7020
Brakes	Tektro MD-C605C
Rotors	Tektro R160S02M 160mm
Ft. derailleur	Microshift SWORD rf-g7020
R. derailleur	Microshift SWORD rd-g7025
Crankset	Microshift SWORD 48/31
Cassette	Microshit CS-H105 11/38
Chain	KMC (X10)
Wheelset	Front & Rear WTB ST i19 TCS 2.0 - 36h / Formula HUB (RX-25/26) Tubless compatible
Tyres	Kenda 700X35c
Saddle	WTB Volt

frame specs

Sizes	XS (48) - S (52) - M (55) - L (58) - XL (60)
Material	Cromor Double Butted Steel
Headset	EC 34/28,6 EC 34/30
Seatpost	Ø 27,2 mm
Seat Clamp	Clamp Ø29,8 mm
BB Shell	BSA 68 mm
Ft. derailleur	Clamp on Ø28,6 mm
Routing	External
Color	Forever Green
Tyre Clear.	Up to 700x40 With Fenders - Up to 700x44 Without Fenders
Fork	Cr-Mo Steel 1" - 1/8
Weight	Frame 2150 g. (size M) Fork 1050 g. (uncut)
Brake	Disc, Post Mount
Dropouts ST	Front QR 100mm - Rear QR 135mm
Highlights	Front Rack Middle Fork - Rear Rack Eyelet / Fender Eyelet

tutto mini silver bootleg

A street-ready hybrid bike that combines elements from BMX, track bikes and gravel to create a uniquely fast and fun ride across city and countryside.



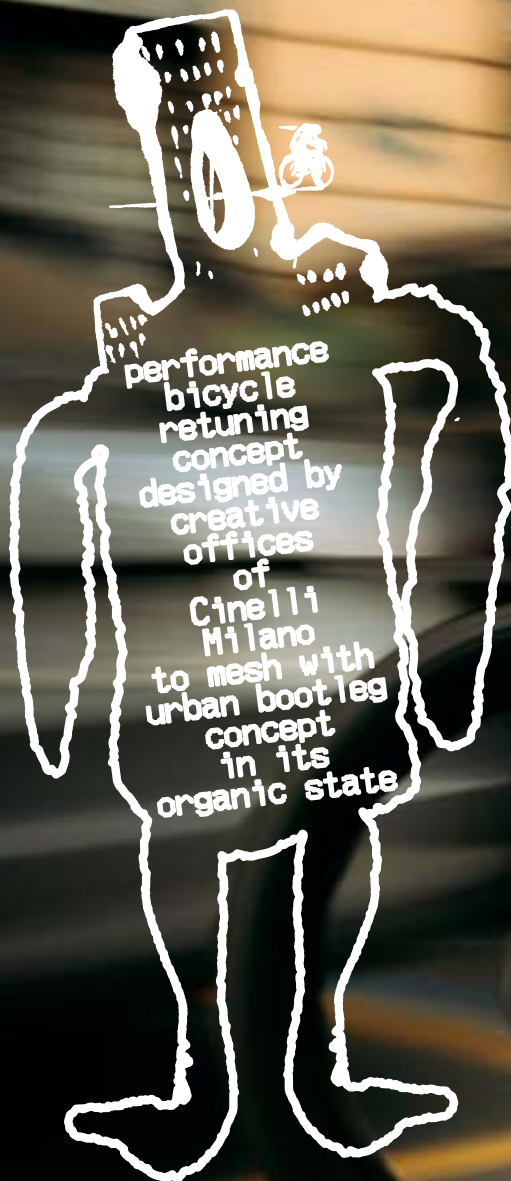

performance
bicycle
retuning
concept
designed by
creative
offices
of
Cinelli
Milano
to mesh with
urban bootleg
concept
in its
organic state

BOOTLEG

silver bootleg concept

Bootleg is conceived of as a treatment applied to what was originally a performance bicycle, retuning its visual appearance as well as technical characteristics for new attempts at escaping the mental and physical limits of the city i.e. NEW STYLES OF URBAN CYCLING. All "Silver Bootleg" colour bikes are characterized by heavy-duty silver paint that mimics the aesthetic of raw aluminium, tone-on-tone raised branding (as though the bike had been stolen and repainted) and reflective details.

The Bootleg treatment has been applied to two famous existing Cinelli models, the Zydeco and the Tutto Plus, as well as the Tutto Mini.

tutto mini silver bootleg

frame-kit - complete bike

- Adjustable disc brake slider dropouts for both fixed gear, single speed and geared setups
- Total 19 eyelets for maximum versatility and cargo-carrying possibilities
- 25c wheels for the best compromise between speed and technical terrain handling, with max clearance for MTB tyres
- BMX-style single speed setup 180mm rise handlebars and 50mm stem
- Belt-drive compatible
- Quick-release seatpost for fast disassembly, increasing transport options
- Vintage American MTB-style segmented fork crown
- Silver Bootleg graphic concept including reflective details and 3D decals



specs

FRAME WEIGHT (M)

2000 g

FORK WEIGHT (M)

1850 g

bottom bracket

BSA

MAX TYRE

20x2,5"

The Tutto Mini is an ultra-hybridized homage to our roots and culture, from BMX to track bikes to gravel. Built on 25c wheels for the best compromise between easy packability, fast accelerations and true technical handling, the Tutto Mini can do anything you want it do: from slick fixed-gear riding to gravel touring to tricks and everyday urban commuting. The Tutto Mini frame is in fact a highly detailed, highly versatile piece of equipment that takes its design cues from our pioneering tracklocross bike, the Tutto Plus and features adjustable disc brake slider dropouts, a total of 19 eyelets, a vintage MTB-style segmented fork crown, reflective details, 3D decals and much, much, more.

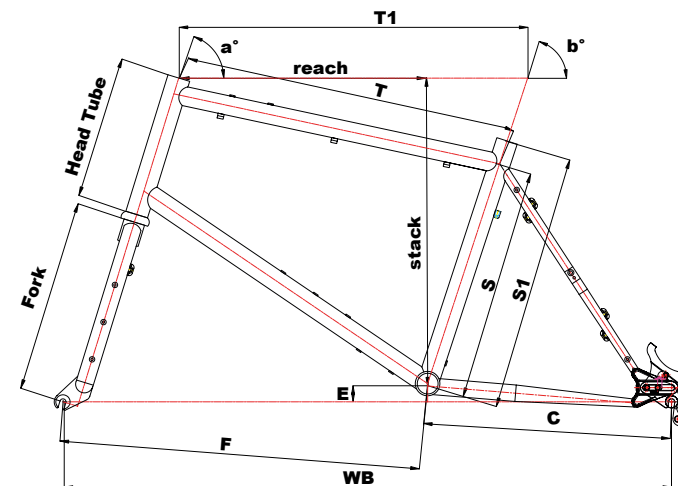

geometry

	S1	S	T1	T	H/T	A	B	R	C	F	WB	E	FORK	STACK	REACH
S	360	320	520	495	185	73	72	25	400	547	945	30	317	455	372
L	420	380	570	544	235	73	72	25	400	596	994	30	317	503	407

assembly

SINGLE SPEED

Drivetrain	/
Handlebar	HL Ø 22,2 - 180 mm Rise / Width 620 mm
Stem	HL Ø 22,2 - Length 50 mm
Seatpost	Cinelli Alloy Ø 31,6 - L 450 mm
Shifters	/
Brakes	Tektro (RS-360A) Lever - Ø 22,2 / Tektro (MD-C605C) Front & Rear
Rotors	Tektro TR 160 mm
Ft. derailleur	/
R. derailleur	/
Crankset	Prowheel Solid 48t / 170 mm
Cassette	Singlespeed 16t
Chain	KMC (410 HA)
Wheelset	Alloy 406x25c - Alloy 6 bolt
Tyres	Odissey Aitken Knobby 20x2.25
Saddle	PVC Saddle Black

frame specs

Sizes	S (36) - L (42)
Material	Steel
Headset	EC 34/28,6 EC 34/30
Seatpost	Ø 31,6 mm
Seat Clamp	Ø 34,9 mm
BB Shell	BSA 68 mm
Ft. derailleur	Clamp Ø 34,9 mm (not included)
Routing	Full External
Color	Silver Bootleg
Tyre Clear.	up to 20x2.5
Fork	Columbus Steel 1-1/8"
Weight	Frame 2000 g. (size M) Fork 1850 g. (uncut)
Brake	Front & Rear Disc PM 160
Dropouts ST	Front QR 100 mm / Rear QR 135 mm
Highlights	Sliding Dropouts, Adventure Eyelets

zydeco silver bootleg

Cinelli's gravel icon goes underground: our best-selling Zydeco is transformed into the ultimate flat-bar and front rack go-everywhere city bike.





zydeco silver bootleg

complete bike

- Heavy duty front rack (max load 8kg)
- Super wide 20mm riser handlebars
- High quality oversized triple-butted aluminium tubing
- Custom rivet system allows user endless further bag and rag options
- Max tyre clearance 700x40c
- Silver Bootleg graphic concept including reflectivedetails and 3D decals

Straight out of the global headquarters of the new Cinelli Bootleg design department comes this: Cinelli's beloved gravel icon, the Zydeco, transformed into the ultimate flat-bar & front-rack go everywhere city bike. Designed to withstand the demands of the most intense urban commuting, the Zydeco Silver bootleg is equipped with a heavy duty aluminium front rack (max load 8kg), firmly anchored to a customized version of Columbus' X carbon fiber fork, super wide 20 mm riser handlebars, 700 x 35c tyres (max tyre clearance 40c), custom rivet system, reflective details, 3D decals and much, much, more.



specs

BIKE WEIGHT **10,3 Kg** BOTTOM BRACKET **BSA** MAX TYRE **40 mm**

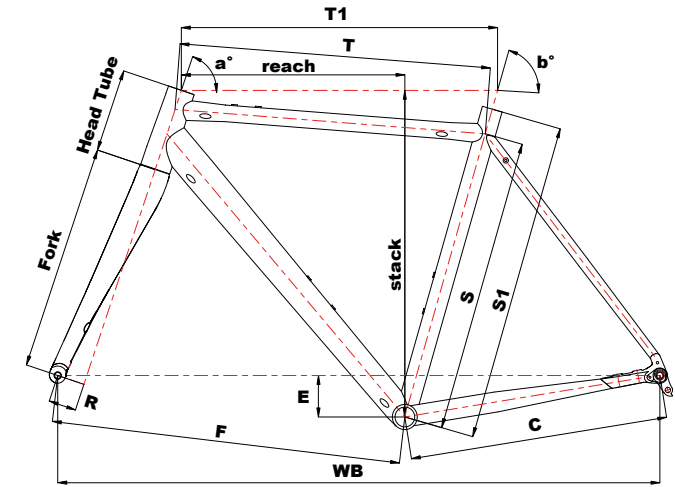

geometry

	S1	S	T1	T	H/T	A	B	R	C	F	WB	E	FORK	STACK	REACH
XS	490	447	510	504	100	70,5	74,5	47	440	580	1010	71	382	510	371
S	510	467	520	514	120	71	74,5	47	440	587	1017	70	382	530	375
M	540	497	539	530	140	71,5	74	47	440	595	1025	70	382	551	380
L	560	517	560	549	160	72	73,5	47	440	606	1037	70	382	572	390
XL	590	547	580	570	180	72,5	73	47	440	617	1047	70	382	592	399

assembly

MICROSHIFT 1X10

Handlebar	Riser Al 6061 / Ø 31,8 / Rise 20mm / Backsweep 6° / Width 680 mm
Stem	Cinelli 6061 Ø 31,8 Angle 6° H 40 mm / XS 90 - S 90 - M 100 - L 110 - XL 110
Seatpost	Cinelli 6061 Ø 31,6 L 350
Shifters	Microshift SL-M9605-R 10 Speed
Brakes	Tektro MD-C510 + Tektro Levers RX-1.0
Rotors	Tektro TR160 160mm
R. derailleur	Microshift RD-M6205AM
Crankset	FSA Omega MegaExo 40t / XS 170 - S 170 - M 172,5 - L 172,5 - XL 175
B. Bracket	FSA BSA68
Cassette	Microshift CS-H104 / 10 Speed / 11-48t
Chain	Kmc X10
Wheelset	Shining (A250) 32h Formula Hub front & rear
Tyres	Kenda 700x35c
Saddle	Cinelli SSM Rnd
Tape	Rubber grip
Rack	O-Stand CD-810 (Included)

frame specs

Sizes	XS (49) - S (51) - M (54) - L (56) - XL (59)
Material	Triple Butted Alloy
Headset	IS 42/28,6 IS 47/33
Seatpost	Ø 31,6 mm
Seat Clamp	Ø 34,9 mm
BB Shell	BSA 68 mm
Ft. derailleur	Clamp Ø 34,9 mm
Routing	Internal
Color	Silver Bootleg
Tyre Clear.	up to 700x40 mm
Fork	Columbus Alu-Carbon1-1/8" - 1-1/4"
Weight	Frame 1760 g. (size M) Fork 600 g. (uncut)
Brake	Flat Mount, Rotor Size Up to 160 mm
Dropouts ST	Rear TA Ø 12x142mm - M12x165 / Front TA Ø 12x100mm - M12x119
Highlights	Front & Rear Fenders Ready / Front & Rear Rack Eyelets / Fast Fuel Eyelets

tutto plus silver bootleg

The original “tracklocross” bike
and the world’s most hybridized
single-speed





tutto plus silver bootleg

complete bike

- Silver Bootleg graphic concept including reflective details and 3D decals
- The original multi-purpose multi-surface track frame
- Track dropouts with rear derailleur braze-ons for geared options
- 45mm fork rake
- Full mudguard eyelets
- Vintage MTB-style segmented fork crown
- Tyre clearance up to 45mm

Tutto Plus is the original do-everything high-performance urban- track frame, in constant evolution since first being launched 8 years ago. The bike can quickly morph from messenger work bike complete with front rack, to alleycat race bike to single-speed cross machine, to indestructible commuter. Made with butted steel tubes, the Tutto has been designed to be able to mount a rear derailleur and a modern road race wheel. A vintage MTB-style segmented TIG welded fork improves rigidity as well as the overall aggressive street-ready aesthetic of the bike and is complemented by the new Silver Bootleg graphic concept including reflective details and 3D decals.



specs

BIKE WEIGHT (M)
10,2 Kg

FORK RAKE
45 mm

BOTTOM BRACKET
BSA

MAX TYRE
45 mm

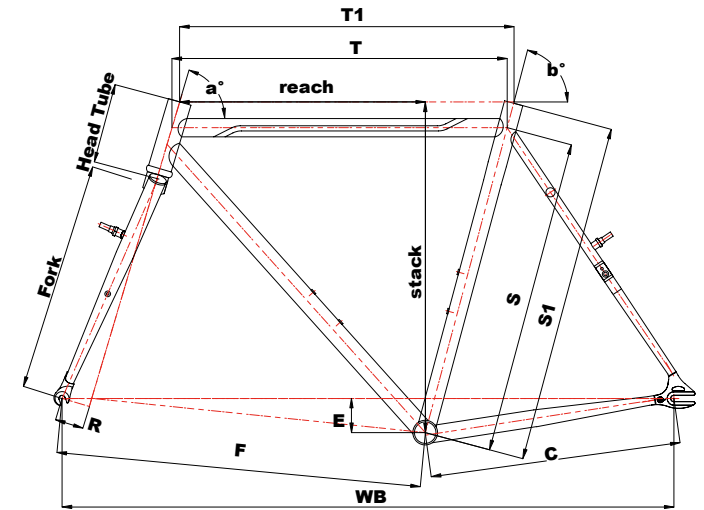

geometry

	S1	S	T1	T	H/T	A	B	R	C	F	WB	E	FORK	STACK	REACH
S	520	480	510	506	90	71,5	75,5	45	425	579	987	60	392	515	378
M	540	500	540	537	100	72,5	75,5	45	425	595	1003	60	392	528	398
L	560	520	560	560	110	72	74,5	45	425	616	1024	60	392	536	410
XL	590	550	585	585	130	73,5	74	45	425	622	1030	60	392	560	424

assembly

SINGLE SPEED

Drivetrain	/
Handlebar	Cinelli Flat Handlebar Ø 31,8 - 15 mm Rise / S 680 - M 680 - L 680 - XL 680
Stem	Cinelli 6061 Ø 31,8 - Angle 6° - H 40 mm / S 90 - M 90 - L 100 - XL 100
Seatpost	Cinelli 6061 Ø 27,2 - L 350 mm
Shifters	/
Brakes	Tektro (CL-330TS) Lever - Ø 22,2 / TX117 V-Brake Front & Rear
Rotors	/
Ft. derailleur	/
R. derailleur	/
Crankset	Lasco CNC 46t / S 170 - M 170 - L 170 - XL 170
Cassette	Shining Singlespeed 18t
Chain	KMC (Z1)
Wheelset	Shining (A-M3) 700C - 32H - KT Hub (DSPF) front / Shining (A-M3) 700C - 32H - KT Hub (5VAR) rear
Tyres	Kenda 700x35c
Saddle	DDK Black

frame specs

Sizes	S (52) - M (54) - L (56) - XL (59)
Material	Steel
Headset	EC 34/28,6 EC 34/30
Seatpost	Ø 27,2 mm
Seat Clamp	Ø 29,8
BB Shell	BSA 68 mm
Ft. derailleur	Clamp Ø 28,6 mm (not included)
Routing	Full External
Color	Silver Bootleg
Tyre Clear.	up to 700x45 mm
Fork	Columbus Steel 1-1/8"
Weight	Frame 2100 g. (size M) Fork 1150 g. (uncut)
Brake	Front & Rear Removable V-Brake Pivot Studs
Dropouts ST	Front QR 100 mm / Rear QR 130 mm
Highlights	Ft. Light Hole / Ft. & Re. Fender, Derailleur Compatibility & Rack Eyelets

vigorelli

The world's most famous track bike, born on the velodrome in Milan but a global cult for weaving through traffic...

Now in an entirely new graphic concept, inspired by a vintage Cinelli Laser unearthed in our archive.





vigorelli

frame-kit

- Pure track reactive geometry (377mm chain stays in all sizes)
- Negative sloping top tube
- Aerodynamic blade seat tube
- Columbus Futura carbon monocoque carbon fork (1-1/8" – 1-1/2")
- UCI-approved for track competition



The new Vigorelli graphic concept simulates the look of a National Cycling Federation track frame that has continued to be used by many different riders (as would often occur with team bikes in national velodromes during the 70s and 80s) who have chosen to continue to add stickers and “restyle” the frame according to new trends and sponsors. Accordingly the frame offers, on top of its two-tone wet-on-wet paint, a layering of “retro” and “hypercontemporary” Cinelli logos and graphic styles.

specs

FRAME WEIGHT (M)	FORK WEIGHT (M)	BOTTOM BRACKET	MAX TYRE	FORK RAKE
1550 g	350 g	BSA	28 mm	45 mm

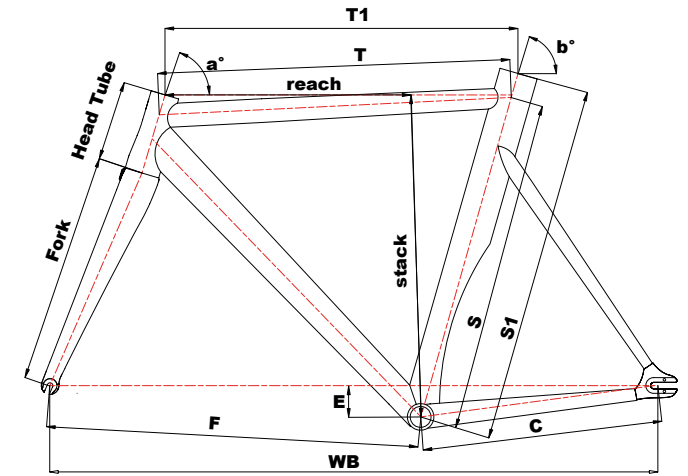

geometry

	S1	S	T1	T	H/T	A	B	R	C	F	WB	E	FORK	STACK	REACH
XS	520	480	500	507	95	73	73,5	45	377	543	914	50	368	478	359
S	550	510	526	535	115	73	74	45	377	572	944	50	368	497	384
M	570	530	558	567	130	73,5	74	45	377	597	968	50	368	514	410
L	590	550	587	598	145	74	74	45	377	622	993	50	368	530	435
XL	605	565	621	632	160	74	73,5	45	377	651	1022	50	368	545	460

frame specs

Sizes	XS (52) - S (55) - M (57) - L (59) - XL (60,5)
Material	Columbus Airplane Triple Butted Alloy
Headset	IS 42/28,6 IS 52/40
Seatpost	Dedicated Aero Alu Seatpost L350
Seat Clamp	Dedicated Aero Seat Clamp
BB Shell	BSA 68 mm
Ft. derailleur	/
Routing	Rear Brake Internal Routing
Color	80's Nazionale Blue
Tyre Clear.	up to 700x28 c
Fork	Columbus Futura Caliper 1-1/8" - 1-1/2" Carbon Monoc.
Weight	Frame 1550 g. (size M) Fork 350 g. (uncut) Seatpost 200 g.
Brake	Standard Rim Brake
Dropouts ST	Front QR 100mm - Rear QR 120mm / Stainless Steel Removable Plates
Highlights	Seatpost / Seatclamp / Headset - Expander

vigorelli steel

A limited edition for the beloved Vigorelli Steel made famous during the hey-day of fixed gear criterium racing.





vigorelli steel

framekit

- Re-issue of an icon
- Identical spec and geometry to original
- Cromor double-buted tubing
- Columbus carbon monocoque Futura fork

For 2025, alongside with the entirely new graphic concept for the Vigorelli, we are thrilled to reintroduce (in a limited edition), the beloved Vigorelli Steel made famous during the hey-day of fixed gear criterium racing.



specs

FRAME WEIGHT (M)	FORK WEIGHT (M)	BOTTOM BRACKET	MAX TYRE	FORK RAKE
1900 g	350 g	BSA	28 mm	45 mm

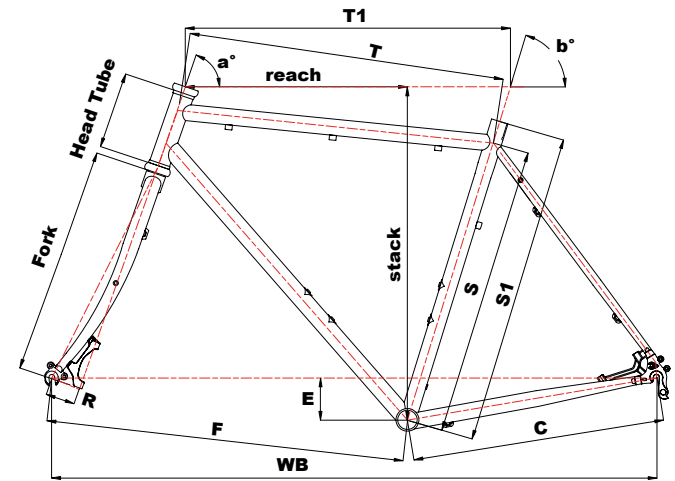

geometry

	S1	S	T1	T	H/T	A	B	R	C	F	WB	E	FORK STACK	REACH	
XS	470	435	512	502	100	72,5	75	45	391	568	953	50	368	498	379
S	500	465	535	526	114	73,5	74,5	45	391	578	965	50	368	515	392
M	530	495	550	543	136	73,5	74	45	391	589	977	50	368	533	397
L	560	525	562	556	156	73,5	73,5	45	391	596	985	50	368	552	399
XL	590	555	575	571	174	74	73	45	391	599	990	50	368	571	400



frame specs

Sizes	XS (47) - S (50) - M (53) - L (56) - XL (59)
Material	Cromor Double Butted Steel
Headset	ZS 44/28,6 EC 44/40
Seatpost	Ø 31,6 mm
Seat Clamp	Clamp Ø33,5 mm
BB Shell	BSA 68 mm
Ft. derailleur	/
Routing	/
Color	80S Team Red - White
Tyre Clear.	700x28c
Fork	Columbus Futura Caliper 1-1/8" - 1-1/2" Carbon Monoc.
Weight	Frame 1900 g. (size M) Fork 350 g. (uncut)
Brake	Caliper
Dropouts ST	Front OLD 100mm - Rear OLD 120mm
Highlights	Frame, Fork, Seat Clamp, Headset



GRUPPO SRL - CINELLI DIVISION
VIA G. DI VITTORIO 21 - 20049 CALEPPIO DI SETTALA (MI) - ITALY
TEL +39-02-95244.1 FAX +39-02-95244.239
www.cinelli-milano.com - info@cinelli-milano.com

The information published in this catalogue are indicative, not binding. Gruppo S.r.l. - Cinelli Division reserves the right to make changes and improvements without prior notice.

aido



